

Motor Brakes

- **Failsafe protection —spring set**
- **Long wear life**
- **Quick, smooth stopping**

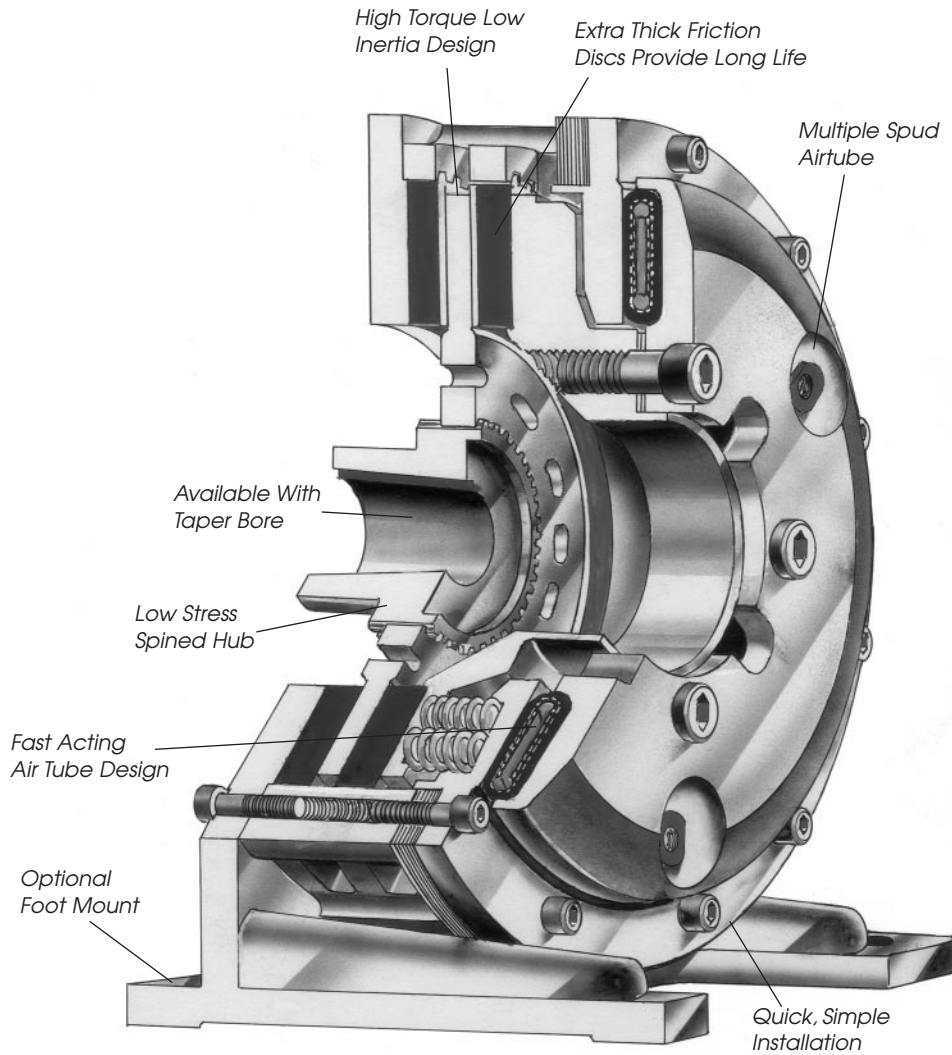

Wichita spring set, air release Motor Brakes are ideal for failsafe protection of process equipment. Available in foot mounted and C-face options, this improved design has thicker friction discs for longer wear life. The fast acting Spring-Set actuation assures quick, smooth stops.

Specifications

Model No. ATD-	Slip Torque Lb. In. .3 CF* Minimum Air-Tube Pressure PSI For Released Brake			*Do Not Exceed 90% Of Slip Torque Ratings — Maximum Horsepower Per 100 RPM Release Pressure - PSI							
	60 (1)	75 (2)	100 (3)	60 PSI Duty				75 PSI Duty			
				A	B	C	D	A	B	C	D
106 MB	2,225	2,900	3,700	3	2.3	1.2	.6	4	3	1.5	.8
206 MB	4,300	5,600	7,200	6	4.4	2.3	1.1	8	5.7	3	1.5
108 MB	3,700	4,800	6,200	5.3	3.8	2	1	7	5	2.6	1.3
208 MB	7,100	9,100	12,000	10	7.3	3.8	2	13	9.3	5	2.5
111 MB	8,200	10,500	11,600	11.7	8.4	4.4	2.2	15	10.7	5.7	2.8
211 MB	15,600	20,000	26,000	22	16	8.4	4.2	28.6	20.5	11	5.4
114 MB	14,500	18,600	24,700	20	15	8	4	26.6	19	10	5
214 MB	27,600	35,400	46,300	39	28	15	7.5	50	36	19	9.5
118 MB	31,400	40,400	51,600	45	32	17	8.5	58	41	22	11
218 MB	60,000	77,000	100,000	86	61	32	16	110	79	41	21
124H MB	75,500	111,000	128,000	108	77	41	20	158	114	60	30
224H MB	137,000	216,000	242,000	196	140	74	37	308	222	117	58

* Max. recommended air pressure – 130 PSI

Model No. ATD-	A	100 PSI Duty		D	Max. Bore Rect. Key Inches	Total Wt. Lbs.	HUB & CP Wt. Lbs.	HUB & CP WR ² #Ft. ²	Effec. WR† Lbs.
106 MB	5	3.8	2	1	2	36.5	6.40	.24	14.0
206 MB	10	7.4	3.9	2	2	49.5	12.17	.46	18.34
108 MB	9	6.3	3.3	1.6	2-3/8	63.23	10.0	.55	26.78
208 MB	17	12.3	6.5	3.2	2-3/8	81.5	16.0	.72	32.03
111 MB	16.6	12	6.3	3.1	2-5/8	96.96	15.0	1.35	40.75
211 MB	37	26	14	7	2-5/8	136.0	30.0	2.60	59.05
114 MB	35	25	13	6.7	4-1/8	157.6	38	5.6	72.3
214 MB	66	47	25	12.5	4-1/8	209.6	65	11	95.3
118 MB	74	53	28	14	5-1/4	322	71	14.5	168
218 MB	143	102	54	27	5-1/4	444	113	27.6	215
124H MB	183	131	69	34	7	690	131	50	377
224H MB	346	248	131	65	7	874	260	101	482

† Weight of internal clutch parts for use in calculating clutch engagement time.



Motor Brakes

Component Parts

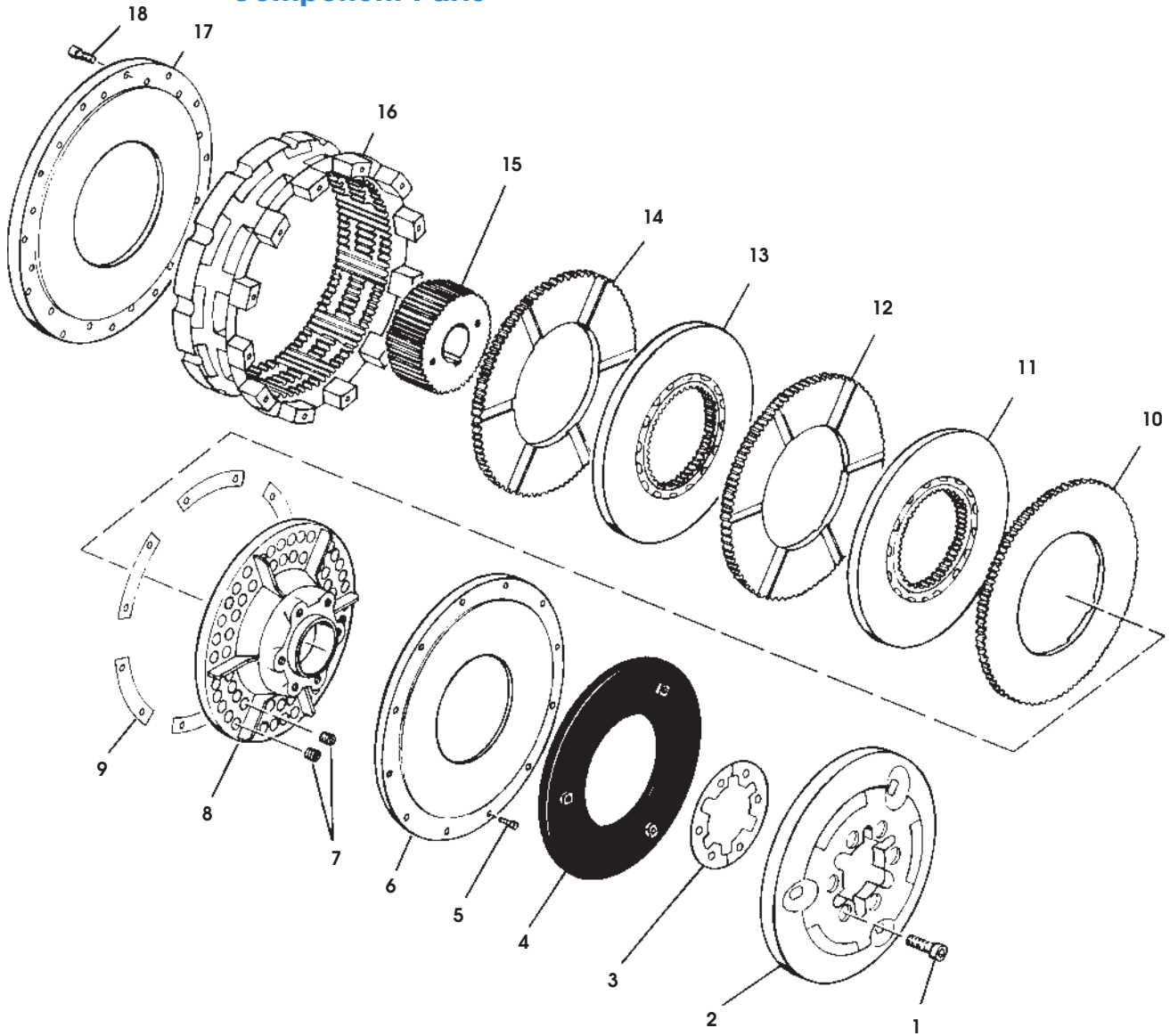

- | | |
|--|--|
| 1. Socket Head Capscrews | 11. Center Plate |
| 2. Air Tube Holding Plate | 12. Grooved Friction Disc
(grooved on both sides) |
| 3. I.D. Shims | 13. Center Plate |
| 4. Airtube | 14. Grooved Friction Disc
(grooved on one side) |
| 5. Socket Head Capscrews | 15. Hub |
| 6. Airtube Spring Plate | 16. Ring |
| 7. Springs | 17. Backplate |
| 8. Spring Release Plate | 18. Socket Head Capscrews |
| 9. O. D. Shims | |
| 10. Grooved Friction Disc
(grooved on one side) | |

C-face motor brakes

- No adjustment
- No lubrication
- Low inertia design
- Rugged, dependable design

C-face adaptors (shaded blue area) are available in standard NEMA T and U frame designs. Custom adaptors are available for your specific motor design. Dimensions G, H, I, J and number of holes need to be provided to Wichita Engineering before final design is completed.

When using Wichita C-Face Motor Brakes in a high cycling application, brake thermal capacity and motor thermal capacity need to be carefully matched. Wichita C-Face Motor Brakes are ideal when paired with Reliance Motors. The motor information chart lists the specific Wichita part numbers for the proper adapter plate and brake for Reliance Motors up to 200 hp.

Contact Wichita Application Engineering for assistance.

Reliance Motor Information

Frame	Max. HP at Std.RPM	Full Load Motor Torque In. Lb.	Steel Adapter Plate	Model No. ATD-
C210	40 / 2500	1008	4-309-075-011-3	7-108-100-113-0 108 MB
C250	60 / 1750	2161	4-309-075-005-3	7-108-100-113-0 108 MB
C280	100 / 1750	3601	4-281-075-015-3	7-111-100-112-0 111 MB
C320	150 / 1750	5402	4-281-075-016-3	7-111-100-112-0 111 MB
C360	200 / 1750	7202	4-271-075-007-3	7-114-100-113-0 114 MB

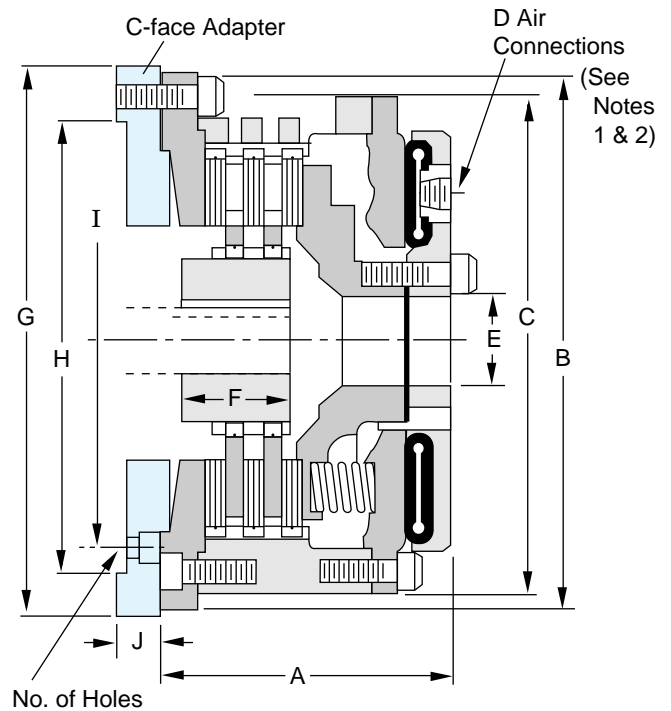

Dimensions (in) (Consult factory for drawing before final layout.)

Model No. ATD-	A	B	C	D	No. of Spuds	E	F
106 MB	5.44	8.75	8.81	1/4" NPT	2	2.00	2.00
206 MB	6.75	8.75	8.81	1/4" NPT	2	2.00	3.25
108 MB	5.82	12.12	11.13	1/2" NPT	2	2.13	1.50
208 MB	7.00	12.12	11.13	1/2" NPT	2	2.13	2.87
111 MB	6.38	16.00	14.75	1/2" NPT	2	3.02	2.00
211 MB	7.75	16.00	14.75	1/2" NPT	2	3.02	3.75
114 MB	7.75	18.75	17.50	1/2" NPT	2	3.88	2.25
214 MB	9.69	18.75	17.50	1/2" NPT	2	3.88	4.25
118 MB	9.01	23.25	22.00	1/2" NPT	3	4.75	2.75
218 MB	10.69	23.25	22.00	1/2" NPT	3	4.75	4.75
124H MB	9.26	30.00	29.00	1/2" NPT	3	8.25	3.13
224H MB	11.94	30.00	29.00	1/2" NPT	3	8.25	5.13

Notes:

1. Quick Release Valves, see page 105.
2. Air Hose Kits, see page 104.

Wichita motor brakes typically produce more torque than is usually necessary. Contact Wichita engineering for help in selecting the number of springs to produce the proper deceleration for your application.

Note: For mounting, use socket head cap screws conforming to the ASTM-574-97a.



Foot mounted motor brakes

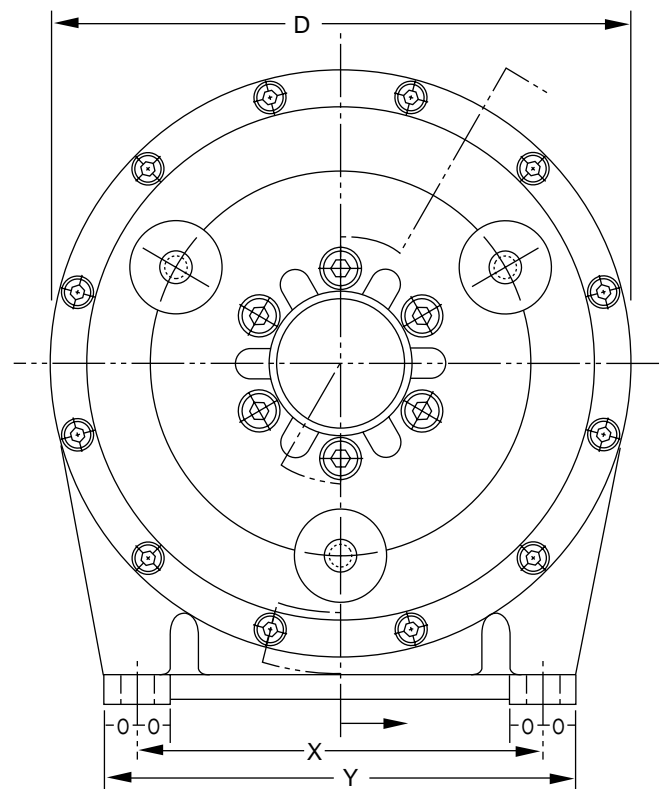
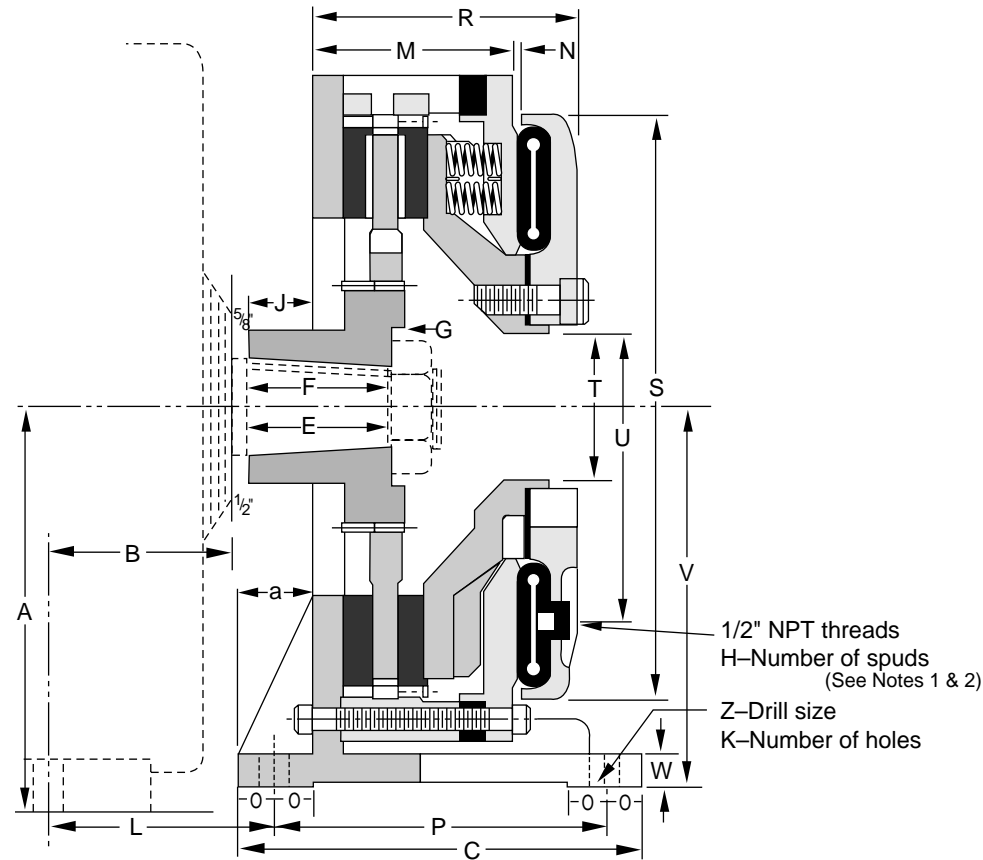

- Notes:**
1. Quick Release Valves, see page 105.
 2. Air Hose Kits, see page 104.

Dimensions (in) (Consult factory for drawing before final layout.)

Motor Frame	Model No. ATD-	A	B	C	D	E	F ±.015	G	H	J	K	L	M
602	108 MB	7-5/8	3-3/4	7-1/2	11-1/8	2-3/4	2.875	3/4	2	1-3/4	4	5-3/8	4-3/4
	208 MB	7-5/8	3-3/4	7-1/2	11-1/8	2-3/4	2.875	1-5/8	2	1-3/4	4	5-3/8	5/16
603	111 MB	8-1/2	4-1/2	8	14-3/4	3-1/4	3.312	3/8	2	1-5/8	4	6-1/8	4-9/16
	211 MB	8-1/2	4-1/2	8	14-3/4	3-1/4	3.312	1-3/8	2	1-5/8	4	6-1/8	5-9/16
604	111 MB	9	5	8	14-3/4	3-1/4	3.312	3/8	2	1-5/8	4	6-5/8	4-9/16
	211 MB	9	5	8	14-3/4	3-1/4	3/312	1-3/8	2	1-5/8	4	6-5/8	5-9/16
606	114 MB	10	5	11	17-1/2	4	4.125	1/2	2	1-1/8	4	6	5-7/16
	214 MB	10	5	11	17-1/2	4	4.125	1-7/8	2	1-1/8	4	6	6-13/16
608	114 MB	11-1/4	5-1/8	11	17-1/2	4-1/2	4.625	1/2	2	1-1/2	4	6-1/2	5-7/16
	214 MB	11-1/4	5-1/8	11	17-1/2	4-1/2	4.625	1-7/8	2	1-1/2	4	6-1/2	6-13/16
610	118 MB	12-1/4	5-3/4	13-1/2	22	4-1/2	4.625	1/2	3	3-1/8	4	8-1/4	8-3/32
	218 MB	12-1/4	5-3/4	13-1/2	22	4-1/2	4.625	2-3/16	3	3-1/8	4	8-1/4	9-25/32
612	118 MB	13-3/8	6-1/4	13-1/2	22	4-3/4	4.875	1/2	3	3-1/8	4	8-3/4	8-3/32
	218 MB	13-3/8	6-1/4	13-1/2	22	4-3/4	4.875	2-3/16	3	3-1/8	4	8-3/4	9-25/32
614	124H MB	14-3/4	7-1/4	23-1/4	29	4-3/4	4.875	1/2	3	2-1/8	4	10-1/8	7-3/16
	224H MB	14-3/4	7-1/4	23-1/4	29	4-3/4	4.875	2-1/4	3	2-1/8	4	10-1/8	8-3/4
616	124H MB	16	8-1/2	23-1/4	29	5-1/4	5.375	1/2	3	2-3/4	4	11-3/8	7-3/16
	224H MB	16	8-1/2	23-1/4	29	5-1/4	5.375	2-1/4	3	2-3/4	4	11-3/8	8-3/4
618	124H MB	17-3/4	8	23-1/4	29	5-3/4	5.875	1/2	3	2-1/4	4	10-7/8	7-3/16
	224H MB	17-3/4	8	23-1/4	29	5-3/4	5.875	2-1/4	3	2-1/4	4	10-7/8	8-3/4

Motor Frame	Model No. ATD-	N	O	P	R	S	T	U	V	W	X	Y	Z	a
602	108 MB	5/16	7/8	5-3/4	5-7/8	9-3/8	1.95	6-5/8	7	3/4	3-1/4	8-1/4	11/16	1-5/8
	208 MB	5/16	7/8	5-3/4	6-3/4	9-3/8	1.95	6-5/8	7	3/4	3-1/4	8-1/4	11/16	1-5/8
603	111 MB	5/16	7/8	6-1/4	6	11-15/16	3	8-1/2	8-3/8	3/4	4	9-3/4	11/16	1-1/2
	211 MB	5/16	7/8	6-1/4	7	11-15/16	3	8-1/2	8-3/8	3/4	4	9-3/4	11/16	1-1/2
604	111 MB	5/16	7/8	6-1/4	6	11-15/16	3	8-1/2	8-3/8	3/4	4	9-3/4	11/16	1-1/2
	211 MB	5/16	7/8	6-1/4	7	11-15/16	3	8-1/2	8-3/8	3/4	4	9-3/4	11/16	1-1/2
606	114 MB	9/16	1	9	7-1/2	14-3/8	3.88	10-3/4	9-7/8	1	5-3/4	13-1/2	13/16	1-3/4
	214 MB	9/16	1	9	8-7/8	14-3/8	3.88	10-3/4	9-7/8	1	5-3/4	13-1/2	13/16	1-3/4
608	114 MB	9/16	1	9	7-1/2	14-3/8	3.88	10-3/4	9-7/8	1	5-3/4	13-1/2	13/16	1-3/4
	214 MB	9/16	1	9	8-7/8	14-3/8	3.88	10-3/4	9-7/8	1	5-3/4	13-1/2	13/16	1-3/4
610	118 MB	3/8	1-1/4	11	10-1/2	19-3/8	4-7/8	14-3/16	12-1/2	1	7-3/4	18	15/16	2-1/2
	218 MB	3/8	1-1/4	11	12-3/16	19-3/8	4-7/8	14-3/16	12-1/2	1	7-3/4	18	15/16	2-1/2
612	118 MB	3/8	1-1/4	11	10-1/2	19-3/8	4-7/8	14-3/16	12-1/2	1	7-3/4	18	15/16	2-1/2
	218 MB	3/8	1-1/4	11	12-3/16	19-3/8	4-7/8	14-3/16	12-1/2	1	7-3/4	18	15/16	2-1/2
614	124H MB	3/8	1-5/8	19	9-7/16	27	8-1/4	21	20-3/4	2	15	33-1/4	1-9/16	2-5/8
	224H MB	3/8	1-5/8	19	11-1/8	27	8-1/4	21	20-3/4	2	15	33-1/4	1-9/16	2-5/8
616	124H MB	3/8	1-5/8	19	9-7/16	27	8-1/4	21	20-3/4	2	15	33-1/4	1-9/16	2-5/8
	224H MB	3/8	1-5/8	19	11-1/8	27	8-1/4	21	20-3/4	2	15	33-1/4	1-9/16	2-5/8
618	124H MB	3/8	1-5/8	19	9-7/16	27	8-1/4	21	20-3/4	2	15	33-1/4	1-9/16	2-5/8
	224H MB	3/8	1-5/8	19	11-1/8	27	8-1/4	21	20-3/4	2	15	33-1/4	1-9/16	2-5/8

Wichita motor brakes typically produce more torque than is usually necessary. Contact Wichita Engineering for help in selecting the number of springs to produce the proper deceleration for your application.

Note: For mounting, use socket head cap screws conforming to the ASTM-574-97a.

Motor Brakes

Air Hose Kits

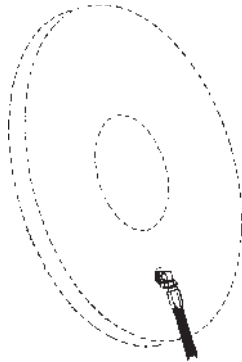

Model	Part Number
8"	8-908-912-100-5 8-908-924-100-5 QRV

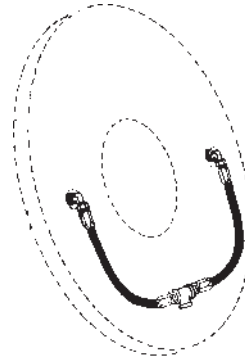

Model	Part Number
6"	8-906-912-200-4 8-906-931-201-5 QRV
8"	8-908-913-200-5 8-908-931-200-5
11"	8-911-913-200-5 8-911-931-200-5 QRV
14"	8-914-913-200-5 8-914-921-200-5 QRV
16"	8-916-913-200-5 8-916-921-200-5 QRV

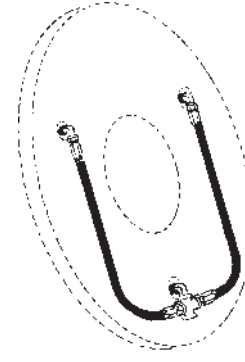

Model	Part Number
18"	8-918-912-200-5 8-918-931-200-5 QRV
21"	8-921-913-200-5 8-921-931-200-5 QRV
24"	8-924-913-200-5 8-924-931-200-5 QRV
27"	8-927-913-200-5 8-927-921-200-5 QRV

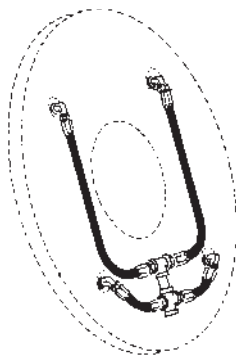

Model	Part Number
30"	8-930-913-400-5 8-930-931-400-5 QRV
36"	8-936-913-400-6 8-936-931-400-6 QRV
42"	8-942-913-400-6 8-924-931-400-6 QRV
48"	8-948-912-400-6 8-948-923-400-6 QRV

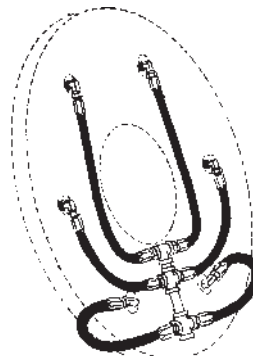

Model	Part Number
60"	8-960-912-500-5 8-960-923-400-6 QRV

Air hose kits contain all necessary parts (fittings, hoses and extensions) to completely plumb the brake air system.

Optional Quick Release Valves can replace elbows on most units (see page 105).



Quick Release Valve

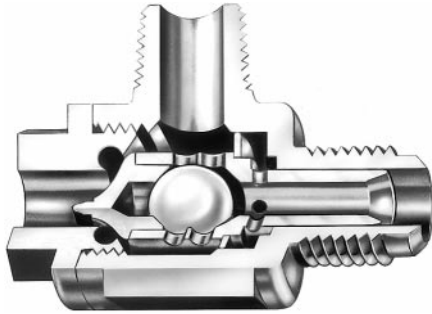

8-263-610-011-1 7/8" - 14 Thread
 8-263-610-021-1 1/2" NPT

The Wichita Springless Quick Release Valve discharges twice as fast as any other valve tested in our laboratory and is four to five times faster than some common makes of valves.

This valve will close and seal with less than 20 lbs. pressure. Most others require 25 to 30 lbs. to definitely seal. In actual tests, the Wichita Valve made many hundreds of thousands of engagements and disengagements before the slightest leak occurred, or any parts needed replacement. Other valves which were tested required major replacement in fewer than 20,000 cycles.

Quality Material

- Body and Cap: High strength aluminum alloy
- Stem: Moulded nylon
- Check Valve: Nylon ball
- "O" Ring: Neoprene

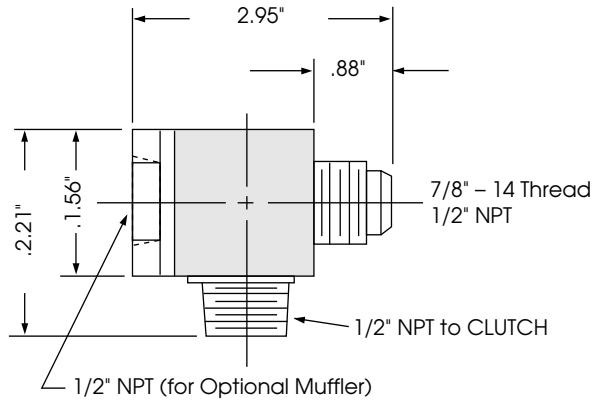

Standard thread arrangement of 1/2" size. 1/2" pipe thread on the tube connection and choice of 1/2" pipe thread, or standard 7/8-14NF thread for flared fitting thread on inlet connection. (Fits standard No. 10 high-pressure hose fitting.)

Roto-couplings

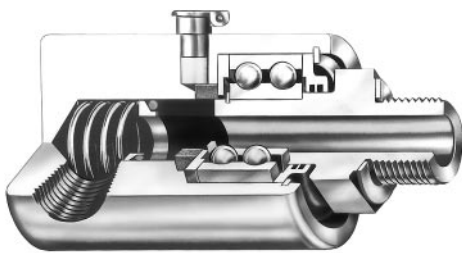

The Wichita Roto-coupling is a device to connect, or couple, a non-rotating air, gas, or fluid line to a rotating shaft.

- Long life, no maintenance.
- Felt seal eliminates bearing contamination.
- Fast, easy installation.

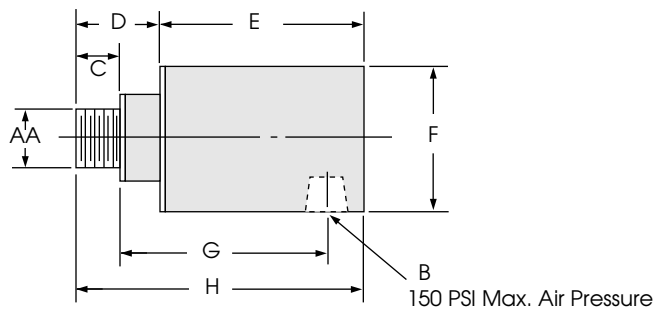

Wichita Part No.	AA	B	C	D	E	F	G	H	Max. R.P.M.
8-240-701-003-1	5/8-18NF	1/4" NPT	.40	1.046	2.250	1.500	2.13	3.297	3500
8-240-705-001-1	1"-14 NF	1/2" NPT	.75	1.250	3.188	2.500	3.00	4.438	3500
8-240-708-001-1	1"-14 NF	3/4" NPT	.75	1.313	4.688	2.875	3.69	5.440	3500
8-240-710-002-1	1-1/2"-12 NF	1" NPT	1.13	1.937	4.875	3.250	3.44	6.812	2500
8-240-712-001-1	2"-12 NF	1-1/2" NPT	1.13	2.813	5.250	4.250	5.38	8.062	2500
8-240-714-001-3	2" NPT	2" NPT	1.50	3.000	7.062	4.625	7.00	10.062	1000
8-240-716-000-3	2-1/2" NPT	2-1/2" NPT	1.88	3.250	9.375	7.000	7.75	12.625	750

Note: All measurements are in inches.



E